

BRAZO LATERAL EXTENSION

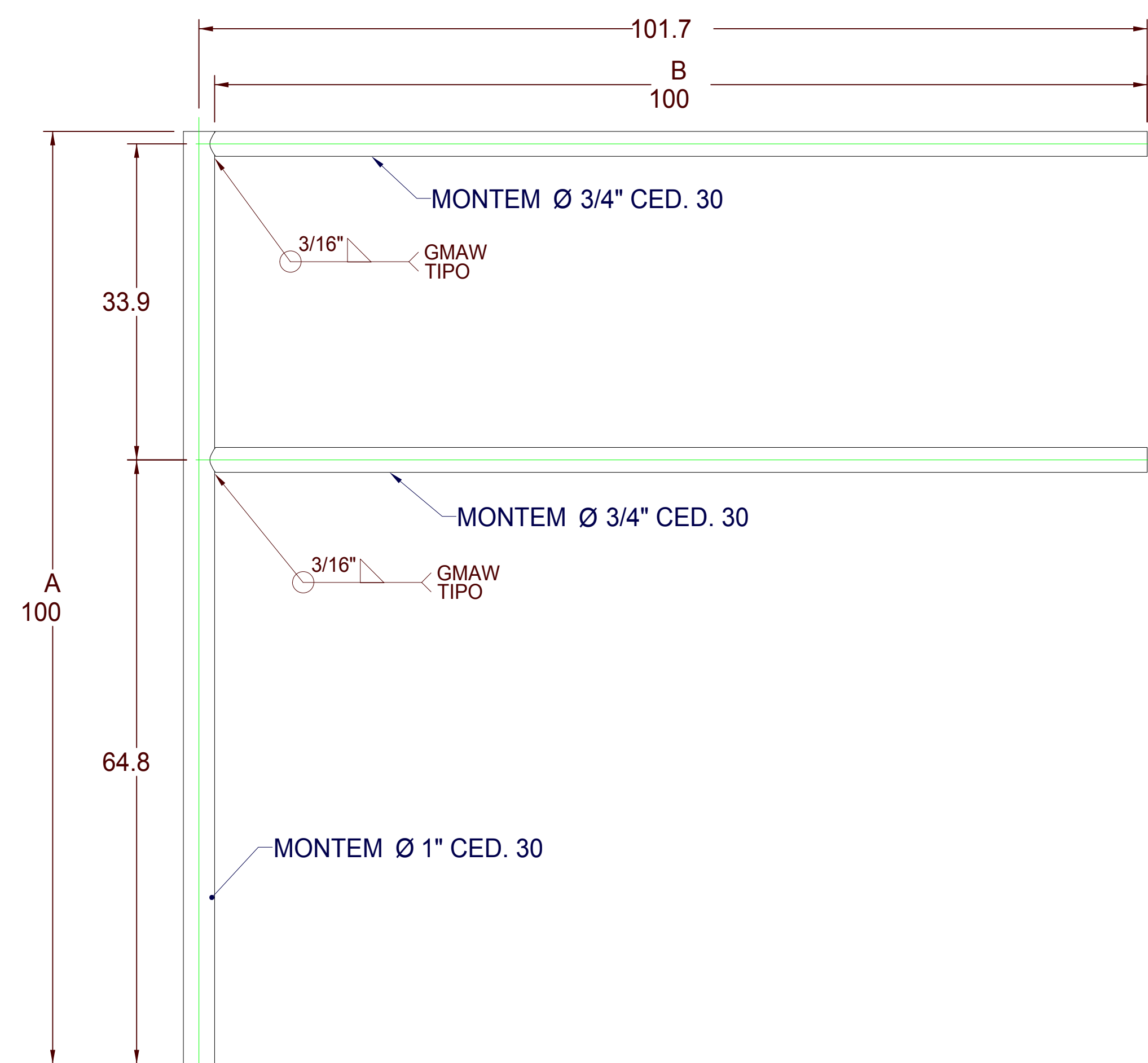

BRAZO LATERAL

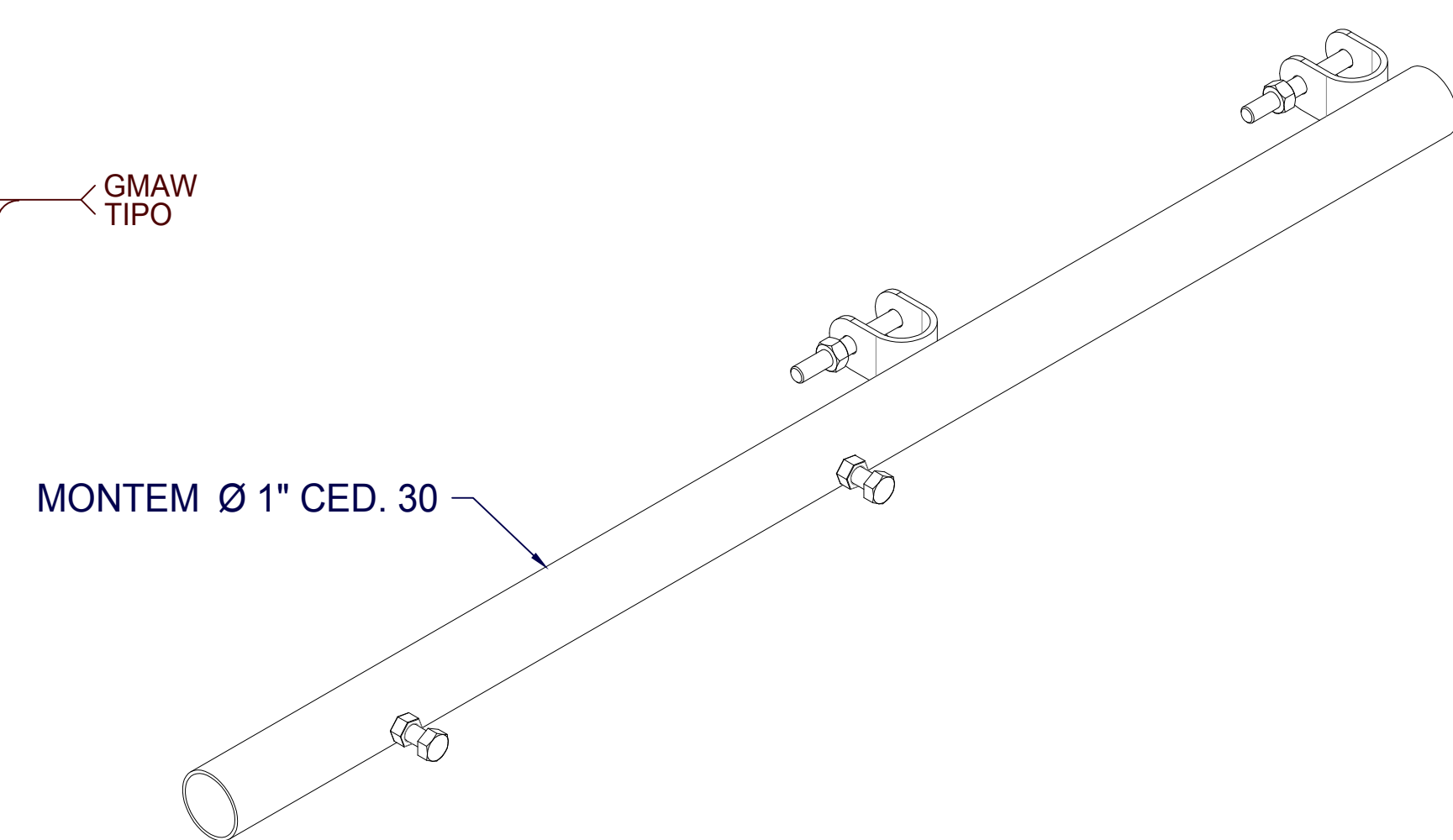
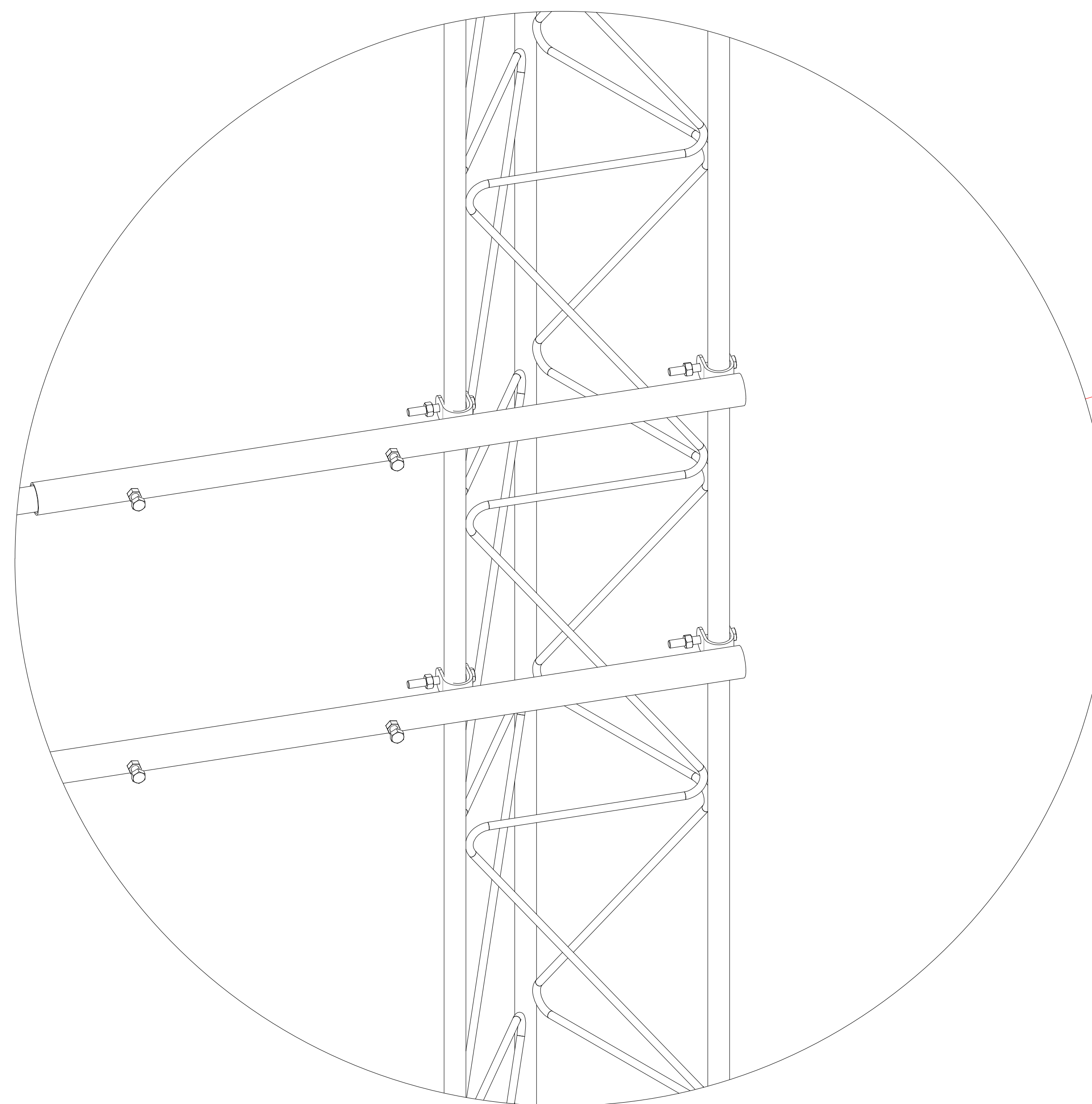

**DETALLE E
ESCALA 2 : 7.5**

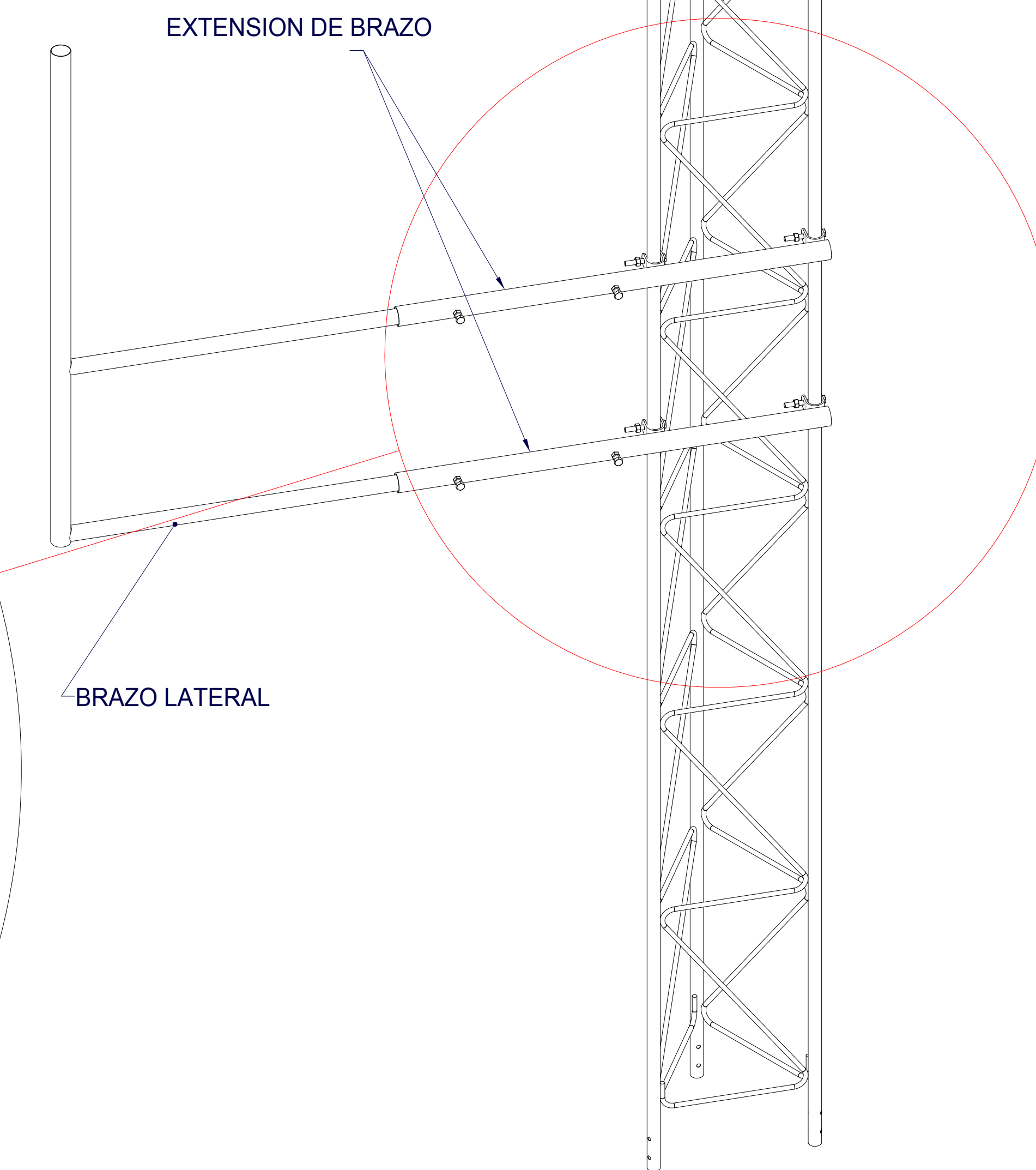

**VISTA ISOMETRICA DE TRAMO STZ30
CON BRAZO LATERAL SBL30**

DESCRIPCIÓN DE PRODUCTO		ACABADO	NOTAS GENERALES
SBL30 - BRAZO LATERAL PARA TORRE DE 30 CM		SBL30G - GALVANIZADO POR INMERSION EN CALIENTE. SBL30 - GALVANIZADO ELECTROLITICO.	1. MEDIDAS EN CENTIMETRO, EXCEPTO INDICADAS. 2. TOLERANCIA GENERAL ± 0.1 cm. 3. TODO MATERIAL ES DE ACERO ASTM - 36. 4. TODA LA SOLDADURA SERA DEL TIPO AWS E7018. 5. LA TORNILLERIA ES GRADO MAQUINA Y/O INOXIDABLE.
NOMBRE PLANO: SBL30-001		ACOTADO: CM	